

4EDCB8S – single mechanical seals to API 682, 4th edition (category 1)

For KSB's MCPK pump type series

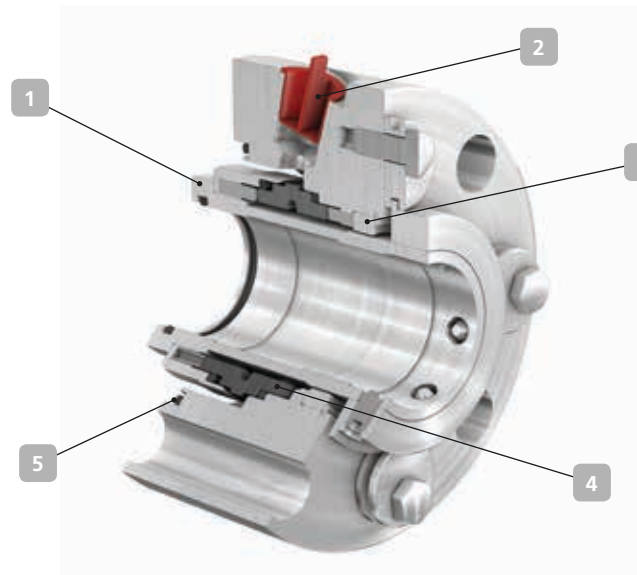

Applications:
chemical and petrochemical industries

Arrangement 1 Contacting, single, product-lubricated and balanced cartridge seal

1 Compact

The single cartridge seal is especially designed for use in the standardised installation spaces of the non-API pump MCPK (CPKN + CPK possible).

2 Flexible

The mechanical seal can be connected to all common API Plans, such as 01, 02, 11, 31, 32 + 61 (62) and 23 + 61 (62).

3 Dependable

Floating throttling bush for optional connection of a gas or steam quench. This prevents outboard incrustations at the seal.

4 Robust

The mechanical seal is available in a hard-soft combination of silicon carbide and carbon graphite, or in a hard-hard combination of silicon carbide and silicon carbide.

5 Materials

The seal contains O-rings as secondary sealing elements. They are available in different material variants.

Technical description

Category	I
Type	A
Arrangement	1
Design	Cartridge
Additional information	Various wear part kits available on request

Materials

Primary ring	"A" carbon (A) / SiC-Si (Q2)
Mating ring	SiC-Si (Q2)
Elastomers	FKM (V) / FFKM (K)
Springs	2.4610 (M)
Other Components	1.4571 (G)
Other material combinations on request	

Technical data

Pressure	Up to 20 bar
Temperature	-10 to 200 °C
Bearing bracket (seal size)	CS40 (033), CS50 (043), CS60 (053), CS80 (065)
Business type	Standard (KSB EasySelect)
Higher application limits on request	