

4EDTMP – for KSB's RPH pump type series

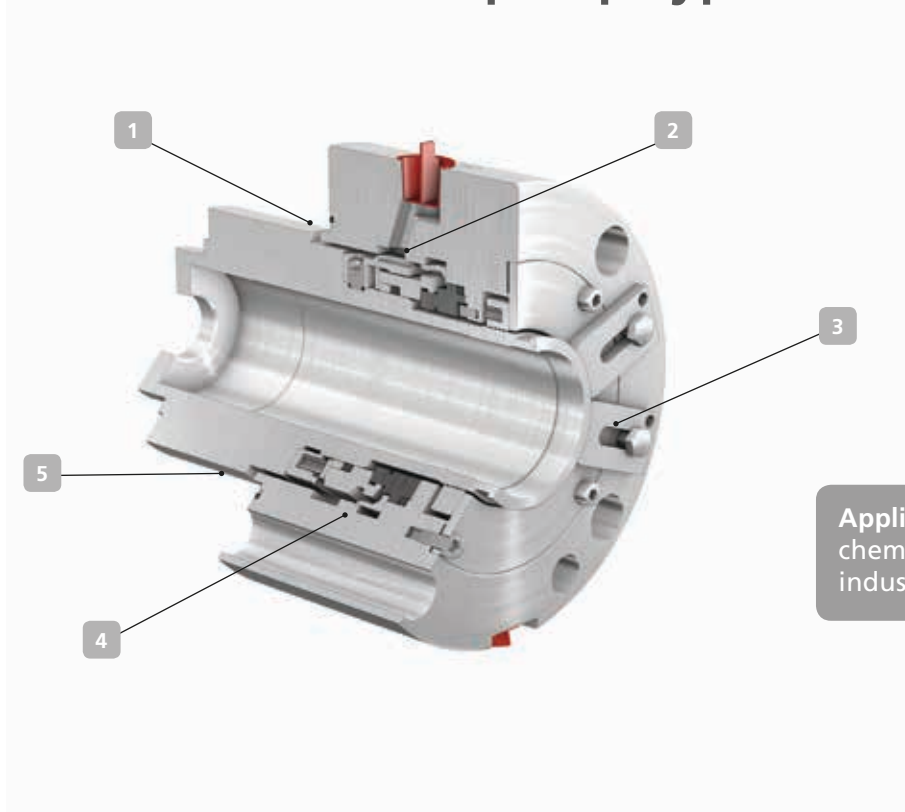

Applications:
chemical and petrochemical
industry

1 Robust

Single mechanical seal, specially developed for hot water applications, with hook sleeve and "thermal barrier".

2 Reliable

The cooled pump cover and cooler (Plan 23) ensure optimum operating conditions in the seal chamber.

3 Versatile

The mechanical seal comes with a floating throttling bush as standard for use with a gas or a steam quench.

4 Dependable

In material variant AQ1KMG the seal can be used for fluids of up to 260 °C and an operating pressure of up to 63 bar/g.

5 Safe

The special design with hook sleeve does away with the need for an axial adjusting dimension; the seal is always perfectly positioned on the pump shaft.

Technical description

Design	Single cartridge seal
Type	Dynamic, balanced
Springs	Multi-spring arrangement
Direction of rotation	Uni-directional
Bearing bracket (seal size)	B02 (050), B03 (060), B05 (079), B06 (100), B07 (120)

Materials

Primary ring	"A" carbon (A)
Mating ring	SiC (Q1)
Elastomers	EPDM (E), FFKM (K)
Springs	2.4610 (M)
Other Components	1.4571 (G)

Technical data

	Variant TMP	Variant THP
Operating pressure	Up to 63 bar	Up to 100 bar
Temperature	Up to 260°C	Up to 260°C
Business type	Standard (KSB Easy Select)	Engineered