

4RPS – for KSB's RPH-RO type series

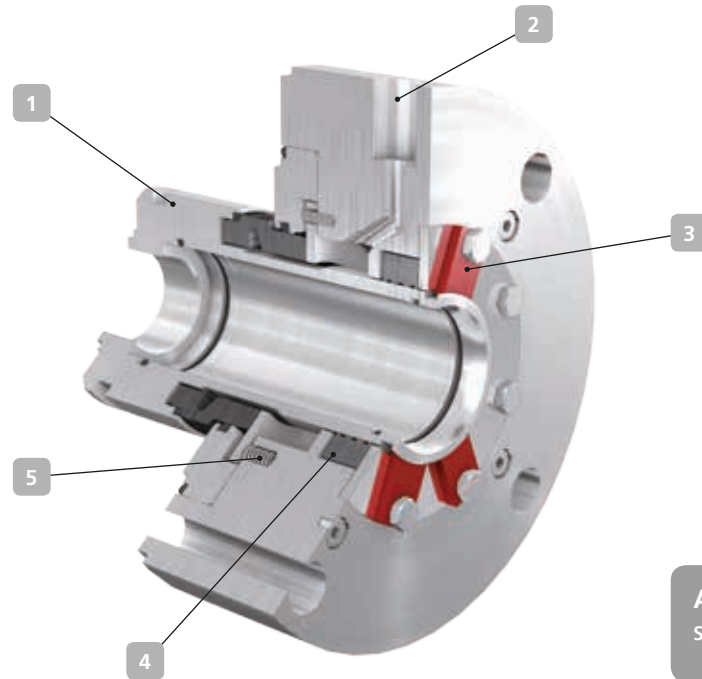

Applications:
seawater

1 Compact

Single cartridge seal, bi-directional and balanced.

2 Robust

The materials and design ensure a long service life. The mechanical seal features threaded connections for flushing out leakage at the atmospheric side.

3 Service-friendly

Tailored to the seal installation space and pump requirements. Easy installation; the assembly fixtures provide for safe transport and pre-centring for installation.

4 Increased safety

An integrated, floating throttling ring provides additional safety in the event of leakage.

5 Dependable

Stationary design, multiple springs located outside the fluid handled

Technical description

Design	Single cartridge seal
Type	Stationary, balanced
Springs	Multi-spring arrangement
Direction of rotation	Bi-directional

Materials

Primary ring	SiC (Q1)
Mating ring	SiC (Q1)
Elastomers	FKM (V)
Springs	2.4610 (M)
Other Components	1.4501 (G4) / 1.4462 (G1)

Other material combinations on request

Technical data

Operating pressure	Up to 70 bar, dynamic Up to 100 bar, static
Temperature	0 °C to 80 °C
Bearing bracket (seal size)	B03L (047), B05L (073)
Business type	Standard (KSB EasySelect)